



Metalastik® type Cushyfoot™

Cushyfoot™ mountings are suitable for many different types of machinery, e.g. diesel engines, generator sets, compressors, fans, hydraulic units and lift machinery.

Features

Cushyfoot™ mountings have two rubber elements, used in shear and compression, to provide excellent stiffness characteristics for the isolation of a wide range of vibration frequencies.

There are three sizes, 17-0290 for loads up to 230 kg per mounting, 17-0213 for loads up to 1250 kg and 17-0346, which will carry up to 1280 kg per mounting, but will provide up to 16 mm static deflection.

The Cushyfoot™ mounting has the following features:

- A wide load range from 50 to 1280 kg.
- Stamped identification plates for product identification.
- Strong castings for safety and reliability.
- Dissimilar horizontal stiffnesses give optimum vibration isolation and motion control.

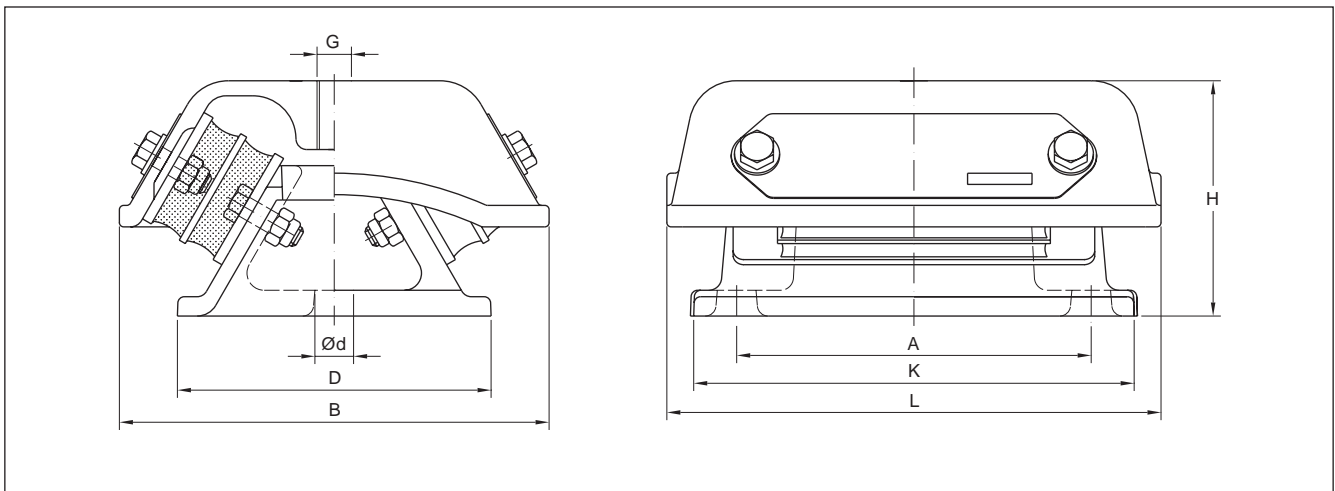
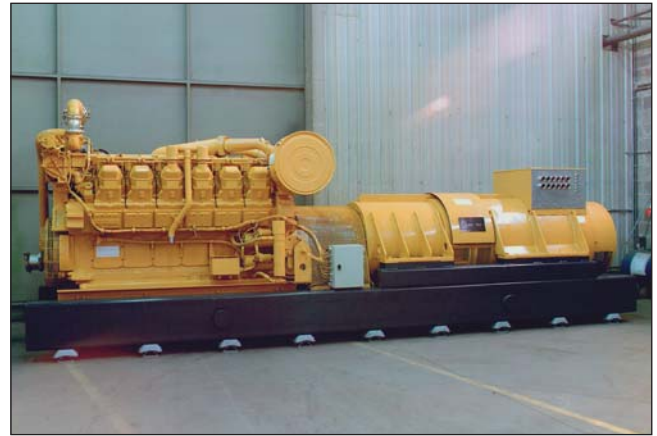

Type	Art.No		Dimensions in mm								Max vertical load (kg)	Weight (kg)
			L	B	A	K	H	D	d	G		
Cushyfoot™ mountings	17-0290-45	(45° IRH)	122	132	90	114	72	82	13	M16	120	2.3
	17-0290-60	(60° IRH)	122	132	90	114	72	82	13	M16	230	2.3
	17-0213-45	(45° IRH)	230	204	165	205	110	148	18	M16	590	10
	17-0213-60	(60° IRH)	230	204	165	205	110	148	18	M16	1250	10
	17-0346-45	(45° IRH)	230	204	165	205	123	148	18	M16	630	9.5
	17-0346-60	(60° IRH)	230	204	165	205	123	148	18	M16	1280	9.5