



**Novibra™ type RAB**

Effective isolation of vibration and noise on different machinery with rotating movements, e.g.

- ¥ Diesel engines
- ¥ Combustion engines
- ¥ Emergency power packs
- ¥ Pumps
- ¥ Industrial gensets
- ¥ Marine gensets

**Features**

Similar in design to the RA/RAEM range, type RAB uses rubber in shear and compression for optimum stiffness characteristics and horizontal stability. Especially effective on small 1, 2 and 3 cylinder diesel engines where the special compound employed provides effective isolation of vibration while eliminating much of the excessive movement normally associated with 1E3 cylinder engines.

Its unique construction and the latest production methods make Novibra™ type RAB a high performance mounting having a number of advantages:

- ¥ Rubber features are utilised effectively combining compression and shear.
- ¥ Tight tolerances on dynamic stiffness rate for accurate vibration calculations.
- ¥ Load rating options, 10-130 kg.
- ¥ Corrosion protected to cope with arduous environments on land or marine applications (Fe/Zn8C as per ISO 2081).
- ¥ Fitted as standard with a shock-proof device with resilient stop, ideal for mobile or marine use. The RAB-mounts can accommodate occasional shock loads to 5 g reference to the weight. The mount will withstand shock loads up to 2 g without plastic deformation.
- ¥ Clear and durable product marking so that mountings can be identified even after several years in operation.
- ¥ Domed shape cover to protect against oil contamination.

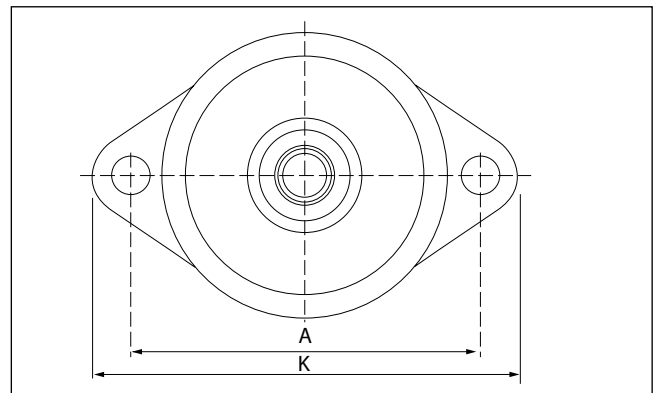
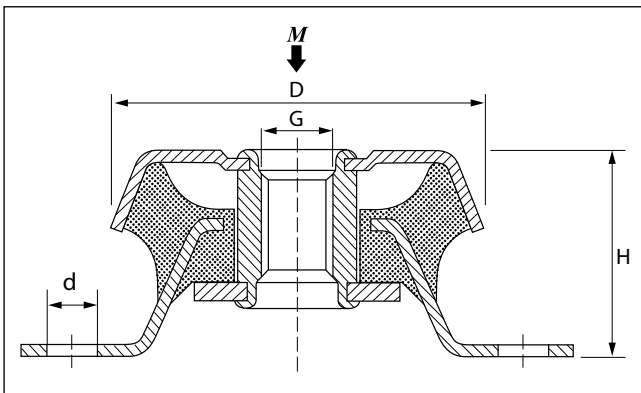

Ar Type	t.No. 55ûIRH	Dimensions mm					Weight		
		D	A	H	K	d	G	kg	M-Max (kg)
RAB-0	2256600	63	76	35	93.5	8.5	M12	0.22	130
RAB-2	2256610	63	76	35	93.5	8.5	M12	0.22	105
RAB-3	2256620	63	76	35	93.5	8.5	M12	0.22	70

Load per mounting (kg)

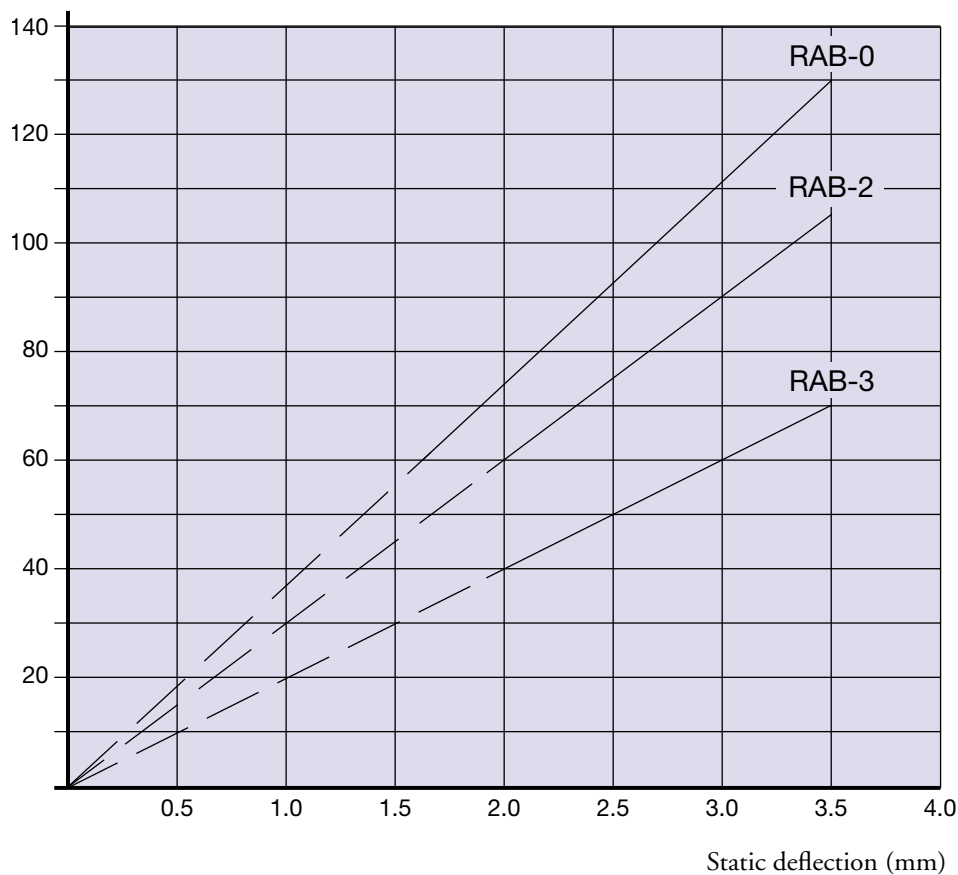

Fully approved by NATO and Europe's leading manufacturers of 1- 2- and 3-cylinder versions of compact diesel engines.



Example of RAB-installation on a 3-cylinder diesel engine power pack.